

# Joint Spacer Clamp FAZ

## TECHNICAL DATA SHEET

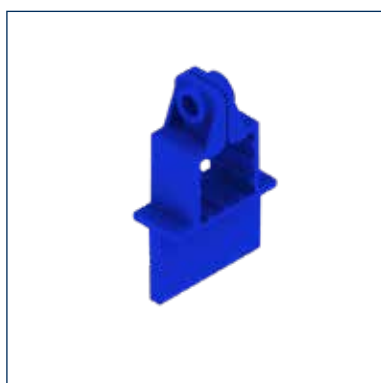

SIHGA® montagepack		Joint Spacer Clamp Type	für SenoFix® II SX Joint Widths	
Art. No.	PU	FAZ	[mm]	
40646	5	6	6,0	yes
40666	5	8	8,0	no
40686	5	10	10,0	no



### DETAILS

- accessories for TerrassenFix® Clamp III
- joint distance either 6, 8, 10 mm
- is placed directly on TerrassenFix® Clamp III

