

L-GoFix[®] MS A2

TECHNICAL DATA SHEET



SIHGA [®]		Dimension	Installation Part	Characteristic Values**			
montagepack	L-GoFix [®] MS A2		AD	Tensile Force F ₁ [kN]		Shear Force F ₂ [kN]	
Art. No.	PU	d1 x L	[mm]	Head	Thread	Wood-Wood	Steel-Wood
22226	400	4,5 x 40	16	0,48	1,55	0,74	1,15
22236	400	4,5 x 45	18	0,48	1,77	0,83	1,21
22246	400	4,5 x 50	20	0,61	1,99	0,92	1,26
22266	400	4,5 x 60	24	0,61	2,36	1,07	1,35
22276	300	4,5 x 70	28	0,61	2,72	1,22	1,45
22316	200	5,0 x 45	18	0,76	1,82	0,89	1,36
22326	200	5,0 x 50	20	0,95	2,14	0,99	1,44
22336	200	5,0 x 60	24	0,95	2,53	1,18	1,54
22346	200	5,0 x 70	28	0,95	2,93	1,33	1,64
22356	200	5,0 x 80	32	0,95	3,72	1,57	1,84
22366	200	5,0 x 90	36	0,95	4,12	1,67	1,94
22376	200	5,0 x 100	40	0,95	4,30	1,72	1,98

Subject to technical modifications and errors. Status of approval 12.2022

** characteristic values for dimensioning according to EC 5 and for strength class p_k 490 kg/m³ (Larch)

Dimension [mm]

L-GoFix[®] MS A2

d1	TX	DK	KS 1	KS 2
4,5	20	6,9	5,2	4,2
5,0	25	8,5	6,0	4,8

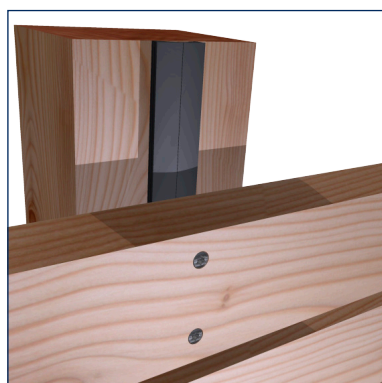
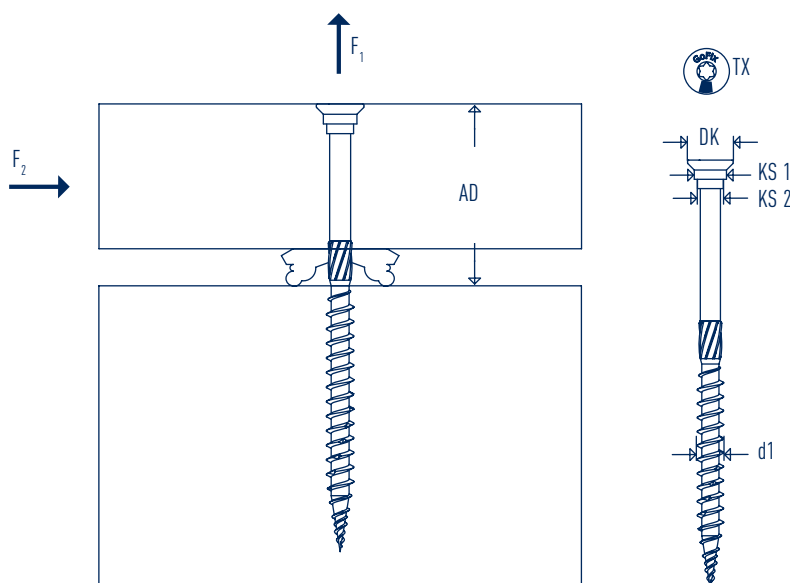

DETAILS

When using coatings such as oils, glazes and pre-greying, it is essential to consult the coating manufacturer. As a rule, the manufacturer specifies the minimum material quality of the binding agent.

If the manufacturer is not known, we recommend material quality A4 (L-BohrFix[®] MB A4).

