

ProziFix®

SIHGA®



* Threaded rod is not included

ProziFix®



SIHGA® Feature

YOUR Benefit

wall anchors for vertically perforated brick	assembly of canopies, carports and pergolas
bridges up to 20 cm insulation	no cumbersome cutting out of insulation necessary
high load-bearing capacity	cannot be achieved with any other customary system
internal pipe insulation	very low heat loss
including sealing disc	reseals the facade
0-6 mm rear ventilation joint	for pergolas that are not covered and so on, a distance of 6 mm should be selected so that the wood can dry, no spacing for covered construction
disc dowels included	for optimal cross shear force transmission, Reinforcement of the embedment strength
anchor pipe with high corrosion resistance	SC 9 coating means high service life
BeziFee® is included	no additional material required
developed and manufactured in Austria	time-saving, practical, precise, complete accessories included



SIHGA® TIP:

The special ProziFix® drill PFB 50 was developed to make the 50 mm hole, as it cuts a clean hole in brick without shattering the brick.



ProziFix® load tables

Senftenbacher 25 VZ Plan

SIHGA®		Dimension		Insulation Thickness	Drilling tool	Characteristic Values		Recommended Values*	
montagepack	d1 x L	d2 / Wall Thickness		D		F _{1c}	F _{2c}	F _{1d}	F _{2d}
Art. No.	PU	[mm]	[mm]	[mm]	ProziFix® Drill PFB 50	Shear Force [kN]	Tensile Force [kN]	Shear Force [kN]	Tensile Force [kN]
55416	5	50 x 300	42,4 / 8	110		6,27	6,5	2,51	1,86
55426	5	50 x 320	42,4 / 8	130		5,88	6,5	2,35	1,86
55436	5	50 x 340	42,4 / 8	150		5,53	6,5	2,21	1,86
55446	5	50 x 360	42,4 / 8	170		5,23	6,5	2,09	1,86
55456	5	50 x 380	42,4 / 8	190		4,95	6,5	1,98	1,86
55466	5	50 x 400	42,4 / 8	210		4,70	6,5	1,88	1,86

Wienerberger Poroton vertically perforated brick Plan-T 24,0-0,9

SIHGA®		Dimension		Insulation Thickness	Drilling tool	Characteristic Values		Recommended Values*	
montagepack	d1 x L	d2 / Wall Thickness		D		F _{1c}	F _{2c}	F _{1d}	F _{2d}
Art. No.	PU	[mm]	[mm]	[mm]	ProziFix® Drill PFB 50	Shear Force [kN]	Tensile Force [kN]	Shear Force [kN]	Tensile Force [kN]
55416	5	50 x 300	42,4 / 8	110		14,19	16,34	5,67	4,67
55426	5	50 x 320	42,4 / 8	130		13,30	16,34	5,32	4,67
55436	5	50 x 340	42,4 / 8	150		12,52	16,34	5,01	4,67
55446	5	50 x 360	42,4 / 8	170		11,82	16,34	4,73	4,67
55456	5	50 x 380	42,4 / 8	190		11,20	16,34	4,48	4,67
55466	5	50 x 400	42,4 / 8	210		10,64	16,34	4,26	4,67

Wienerberger Poroton flat brick T8-50,0

SIHGA®		Dimension		Insulation Thickness	Drilling tool	Characteristic Values		Recommended Values*	
montagepack	d1 x L	d2 / Wall Thickness		D		F _{1c}	F _{2c}	F _{1d}	F _{2d}
Art. No.	PU	[mm]	[mm]	[mm]	ProziFix® Drill PFB 50	Shear Force [kN]	Tensile Force [kN]	Shear Force [kN]	Tensile Force [kN]
55406	5	50 x 190	42,4 / 8	0		14,70	6,76	5,88	1,93
55416	5	50 x 300	42,4 / 8	110		9,31	6,76	3,72	1,93

Wienerberger Porotherm 25-38 Plan

SIHGA®		Dimension		Insulation Thickness	Drilling tool	Characteristic Values		Recommended Values*	
montagepack	d1 x L	d2 / Wall Thickness		D		F _{1c}	F _{2c}	F _{1d}	F _{2d}
Art. No.	PU	[mm]	[mm]	[mm]	ProziFix® Drill PFB 50	Shear Force [kN]	Tensile Force [kN]	Shear Force [kN]	Tensile Force [kN]
55416	5	50 x 300	42,4 / 8	110		8,74	13,27	3,50	3,79
55426	5	50 x 320	42,4 / 8	130		8,19	13,27	3,28	3,79
55436	5	50 x 340	42,4 / 8	150		7,71	13,27	3,08	3,79
55446	5	50 x 360	42,4 / 8	170		7,28	13,27	2,91	3,79
55456	5	50 x 380	42,4 / 8	190		6,90	13,27	2,76	3,79
55466	5	50 x 400	42,4 / 8	210		6,56	13,27	2,62	3,79

*For installation in dry concrete or masonry and a temperature range I according to ETA 17/0181 and ETA 17/0182 (minimum temperature -40° C, maximum short-term temperature +40° C; maximum long-term temperature +24° C). Valid for the minimum edge & axis distances given in the table.

Reductions of the recommended values are applied as follows:

Reduction by the factor $\beta_{FT} = 0.7$ is required for damp substrates or a temperature range II according to ETA 17/0181 and ETA 17/0182 (minimum temperature -40° C, maximum short-term temperature +80° C; maximum long-term temperature +50° C) F_{1d} and F_{2d}. F_{2d} must then be reduced by the factor $\beta_{duration} = 0.6$ if the proportion of the permanently acting tractive load is higher than 50%. Material coefficients of γ_M of 2.5 for brick and 1.5 for concrete are already taken into account for F_{1d} and F_{2d}. An installation safety factor γ_{inst} of 1.4 is already taken into account for tractive load F_{2d}. This does not apply for shear forces F_{1d}. For load cases not covered in this table, the underlying expert opinion of MPA Stuttgart is available at www.sihga.com.

Wienerberger Porotherm 50-20 H.i. Plan

SIHGA®		Dimension		Insulation Thickness	Drilling tool	Characteristic Values		Recommended Values*	
montagepack	d1 x L	d2 / Wall Thickness		D		F _{1c}	F _{2c}	F _{1d}	F _{2d}
Art. No.	PU	[mm]	[mm]	[mm]		Shear Force [kN]	Tensile Force [kN]	Shear Force [kN]	Tensile Force [kN]
55406	5	50 x 190	42,4 / 8	0	ProziFix® Drill PFB 50	8,10	2,32	3,24	0,66
55416	5	50 x 300	42,4 / 8	110		5,13	2,32	2,05	0,66

Pichler PIAplan 25/38 VZ

SIHGA®		Dimension		Insulation Thickness	Drilling tool	Characteristic Values		Recommended Values*	
montagepack	d1 x L	d2 / Wall Thickness		D		F _{1c}	F _{2c}	F _{1d}	F _{2d}
Art. No.	PU	[mm]	[mm]	[mm]		Shear Force [kN]	Tensile Force [kN]	Shear Force [kN]	Tensile Force [kN]
55416	5	50 x 300	42,4 / 8	110	ProziFix® Drill PFB 50	8,55	5,86	3,42	1,67
55426	5	50 x 320	42,4 / 8	130		8,02	5,86	3,21	1,67
55436	5	50 x 340	42,4 / 8	150		7,54	5,86	3,02	1,67
55446	5	50 x 360	42,4 / 8	170		7,13	5,86	2,85	1,67
55456	5	50 x 380	42,4 / 8	190		6,75	5,86	2,70	1,67
55466	5	50 x 400	42,4 / 8	210		6,41	5,86	2,57	1,67

Pichler PIAplan 50/20 VZ

SIHGA®		Dimension		Insulation Thickness	Drilling tool	Characteristic Values		Recommended Values*	
montagepack	d1 x L	d2 / Wall Thickness		D		F _{1c}	F _{2c}	F _{1d}	F _{2d}
Art. No.	PU	[mm]	[mm]	[mm]		Shear Force [kN]	Tensile Force [kN]	Shear Force [kN]	Tensile Force [kN]
55406	5	50 x 190	42,4 / 8	0	ProziFix® Drill PFB 50	2,40	3,15	0,96	0,90
55416	5	50 x 300	42,4 / 8	110		1,52	3,15	0,61	0,90

Leitl Vital Plan 25/30/24,9 cm N+F

SIHGA®		Dimension		Insulation Thickness	Drilling tool	Characteristic Values		Recommended Values*	
montagepack	d1 x L	d2 / Wall Thickness		D		F _{1c}	F _{2c}	F _{1d}	F _{2d}
Art. No.	PU	[mm]	[mm]	[mm]		Shear Force [kN]	Tensile Force [kN]	Shear Force [kN]	Tensile Force [kN]
55416	5	50 x 300	42,4 / 8	110	ProziFix® Drill PFB 50	8,74	5,75	3,50	1,64
55426	5	50 x 320	42,4 / 8	130		8,19	5,75	3,28	1,64
55436	5	50 x 340	42,4 / 8	150		7,71	5,75	3,08	1,64
55446	5	50 x 360	42,4 / 8	170		7,28	5,75	2,91	1,64
55456	5	50 x 380	42,4 / 8	190		6,90	5,75	2,76	1,64
55466	5	50 x 400	42,4 / 8	210		6,56	5,75	2,62	1,64

Leitl Vital Solex Plan 50/20/24,9 cm N+F

SIHGA®		Dimension		Insulation Thickness	Drilling tool	Characteristic Values		Recommended Values*	
montagepack	d1 x L	d2 / Wall Thickness		D		F _{1c}	F _{2c}	F _{1d}	F _{2d}
Art. No.	PU	[mm]	[mm]	[mm]		Shear Force [kN]	Tensile Force [kN]	Shear Force [kN]	Tensile Force [kN]
55406	5	50 x 190	42,4 / 8	0	ProziFix® Drill PFB 50	2,40	4,45	0,96	1,27
55416	5	50 x 300	42,4 / 8	110		1,52	4,45	0,61	1,27

*For installation in dry concrete or masonry and a temperature range I according to ETA 17/0181 and ETA 17/0182 (minimum temperature -40° C, maximum short-term temperature +40° C; maximum long-term temperature +24° C). Valid for the minimum edge & axis distances given in the table.

Reductions of the recommended values are applied as follows:

Reduction by the factor $\beta_{FT} = 0.7$ is required for damp substrates or a temperature range II according to ETA 17/0181 and ETA 17/0182 (minimum temperature -40° C, maximum short-term temperature +80° C; maximum long-term temperature +50° C) F_{1d} and F_{2d}. F_{2d} must then be reduced by the factor $\beta_{duration} = 0.6$ if the proportion of the permanently acting tractive load is higher than 50%. Material coefficients of γ_M of 2.5 for brick and 1.5 for concrete are already taken into account for F_{1d} and F_{2d}. An installation safety factor γ_{inst} of 1.4 is already taken into account for tractive load F_{2d}. This does not apply for shear forces F_{1d}. For load cases not covered in this table, the underlying expert opinion of MPA Stuttgart is available at www.sihga.com.

EDER Plan XP 50 plus

SIHGA®		Dimension		Insulation Thickness	Drilling tool	Characteristic Values		Recommended Values*	
montagepack	d1 x L	d2 / Wall Thickness		D		F _{1c}	F _{2c}	F _{1d}	F _{2d}
Art. No.	PU	[mm]	[mm]	[mm]		Shear Force [kN]	Tensile Force [kN]	Shear Force [kN]	Tensile Force [kN]
55406	5	50 x 190	42,4 / 8	0	ProziFix® Drill PFB 50	5,30	5,7	2,12	1,63
55416	5	50 x 300	42,4 / 8	110		3,36	5,7	1,34	1,63

H+H solid lime sand brick 2 DF

SIHGA®		Dimension		Insulation Thickness	Drilling tool	Characteristic Values		Recommended Values*	
montagepack	d1 x L	d2 / Wall Thickness		D		F _{1c}	F _{2c}	F _{1d}	F _{2d}
Art. No.	PU	[mm]	[mm]	[mm]		Shear Force [kN]	Tensile Force [kN]	Shear Force [kN]	Tensile Force [kN]
55416	5	50 x 300	42,4 / 8	110	ProziFix® Drill PFB 50 or 50 mm Hammer Drill	22,61	20,56	9,04	5,87
55426	5	50 x 320	42,4 / 8	130		21,20	20,56	8,48	5,87
55436	5	50 x 340	42,4 / 8	150		19,95	20,56	7,98	5,87
55446	5	50 x 360	42,4 / 8	170		18,84	20,56	7,54	5,87
55456	5	50 x 380	42,4 / 8	190		17,85	20,56	7,14	5,87
55466	5	50 x 400	42,4 / 8	210		16,96	20,56	6,78	5,87

C20/25 cracked and non-cracked slab > 20 cm front side

SIHGA®		Dimension		Insulation Thickness	Drilling tool	Characteristic Values		Recommended Values*	
montagepack	d1 x L	d2 / Wall Thickness		D		F _{1c}	F _{2c}	F _{1d}	F _{2d}
Art. No.	PU	[mm]	[mm]	[mm]		Shear Force [kN]	Tensile Force [kN]	Shear Force [kN]	Tensile Force [kN]
55416	5	50 x 300	42,4 / 8	110	50 mm Hammer Drill	10,89	10,45	7,26	4,98
55426	5	50 x 320	42,4 / 8	130		10,21	10,45	6,81	4,98
55436	5	50 x 340	42,4 / 8	150		9,61	10,45	6,41	4,98
55446	5	50 x 360	42,4 / 8	170		9,08	10,45	6,05	4,98
55456	5	50 x 380	42,4 / 8	190		8,60	10,45	5,73	4,98
55466	5	50 x 400	42,4 / 8	210		8,17	10,45	5,45	4,98

C20/25 cracked and non-cracked slab > 25 cm front side or wall surface

SIHGA®		Dimension		Insulation Thickness	Drilling tool	Characteristic Values		Recommended Values*	
montagepack	d1 x L	d2 / Wall Thickness		D		F _{1c}	F _{2c}	F _{1d}	F _{2d}
Art. No.	PU	[mm]	[mm]	[mm]		Shear Force [kN]	Tensile Force [kN]	Shear Force [kN]	Tensile Force [kN]
55416	5	50 x 300	42,4 / 8	110	50 mm Hammer Drill	12,92	10,45	8,61	4,98
55426	5	50 x 320	42,4 / 8	130		12,11	10,45	8,08	4,98
55436	5	50 x 340	42,4 / 8	150		11,40	10,45	7,60	4,98
55446	5	50 x 360	42,4 / 8	170		10,77	10,45	7,18	4,98
55456	5	50 x 380	42,4 / 8	190		10,20	10,45	6,80	4,98
55466	5	50 x 400	42,4 / 8	210		9,69	10,45	6,46	4,98

*For installation in dry concrete or masonry and a temperature range I according to ETA 17/0181 and ETA 17/0182 (minimum temperature -40° C, maximum short-term temperature +40° C; maximum long-term temperature +24° C). Valid for the minimum edge & axis distances given in the table.

Reductions of the recommended values are applied as follows:

Reduction by the factor $\beta_{FT} = 0.7$ is required for damp substrates or a temperature range II according to ETA 17/0181 and ETA 17/0182 (minimum temperature -40° C, maximum short-term temperature +80° C; maximum long-term temperature +50° C) F_{1d} and F_{2d}. F_{2d} must then be reduced by the factor $\beta_{duration} = 0.6$ if the proportion of the permanently acting tractive load is higher than 50%. Material coefficients of γ_M of 2.5 for brick and 1.5 for concrete are already taken into account for F_{1d} and F_{2d}. An installation safety factor γ_{inst} of 1.4 is already taken into account for tractive load F_{2d}. This does not apply for shear forces F_{1d}. For load cases not covered in this table, the underlying expert opinion of MPA Stuttgart is available at www.sihga.com.

ProziFix[®] brick dimensions, axis and edge distances

	Length l [cm]	Height h [cm]	Thickness d [cm]	$f_{b,min}/f_{c,min}$ [N/mm ²]	Edge distances C ₁ /C ₂ [cm]	Axis distances S ₁ /S ₂
Senftenbacher 25 VZ Plan	38,0	24,9	25,0	15,0	19,0/12,5	U/h
Wienerberger Poroton Vertical perforated brick Plan-T 24,0-0,9	37,3	24,9	24,0	12,0	18,7/12,5	U/h
Wienerberger Poroton Poroton flat brick T8-50,0	24,8	24,9	50,0	6,0	12,4/12,5	U/h
Wienerberger Porotherm 25-38 Plan	37,5	24,9	25,0	10,0	18,8/12,5	U/h
Wienerberger Porotherm 50-20 H.i. Plan	20,0	24,9	50,0	7,5	10,0/12,5	U/h
Pichler PIAplan 25/38 VZ	38,0	24,9	25,0	15,0	19,0/12,5	U/h
Pichler PIAplan 50/20 VZ	20,0	24,9	50,0	10,0	10,0/12,5	U/h
Leitl Vital Plan 25/30/24,9 cm N+F	30,0	24,9	25,0	15,0	15,0/12,5	U/h
Leitl Vital Solex Plan 50/20/24,9 cm N+F	20,0	24,9	50,0	7,5	10,0/12,5	U/h
EDER Plan XP 50 plus	20,0	24,9	50,0	5,0	10,0/12,5	U/h
H+H Solid lie sand brick 2 DF	11,5	11,3	24,0	20,0	5,8/5,7	U/h
Concrete slab front side > 20 cm	40,0	20,0	25,0	C20/25	20,0/10,0	U/h
Betondecke stirnseitig > 25 cm	50,0	25,0	25,0	C20/25	25,0/12,5	U/h

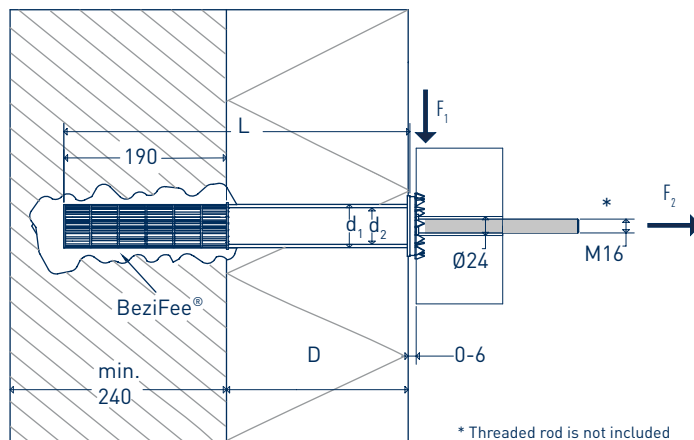

ProziFix® Drill PFB 50

SIHGA® Feature

special cutting geometry

all blades are exchangeable

extra long shaft, compatible with IdeFix® Drill Gauge IBG

can be used with common cordless screwdrivers

manufactured in Austria

YOUR Benefit

cuts a 50 mm hole in bricks without destroying them

saves time and money

hole depths are precisely adjustable and the hole can be drilled cleanly at a right angle

no hammer drill device required

highest European quality and value creation

SIHGA®		ProziFix® Drill PFB 50	
montagepack		∅ x L	Working Length
Art. No.	PU	[mm]	[mm]
55206	1	50 x 620	400

SIHGA®		IdeFix® Drill Gauge IBG
montagepack		∅ x L
Art. No.	PU	[mm]
33666	1	90 x 130



SIHGA® TIP:

When drilling with the ProziFix® Drill PFB 50, the IdeFix® Drill Gauge IBG is recommended in order to be able to maintain the exact depth.



Compared with Threaded Rod

System	Wall Thickness	Distance Threaded Rod	Threaded Rod	Anchoring Depth (with adhesive mortar)	Wood Spacing Holder (L x W x H)	Failure Load	Failure Type	Max. Load*
	[mm]	[mm]	[mm]	[mm]	[mm]	[kN]		[kN]
Threaded Rod	250	200	M 16	150	200 x 140 x 140	~ 1.20	Brick breakage	~ 0.4
ProziFix® 210	250	200	-	190	-	~ 7.50	Brick breakage	1.80

* failure value with partial safety factors reduced (Senftenbacher 25 VZ Plan)

